

A SERIES REPLACEMENT PARTS DIAGRAM

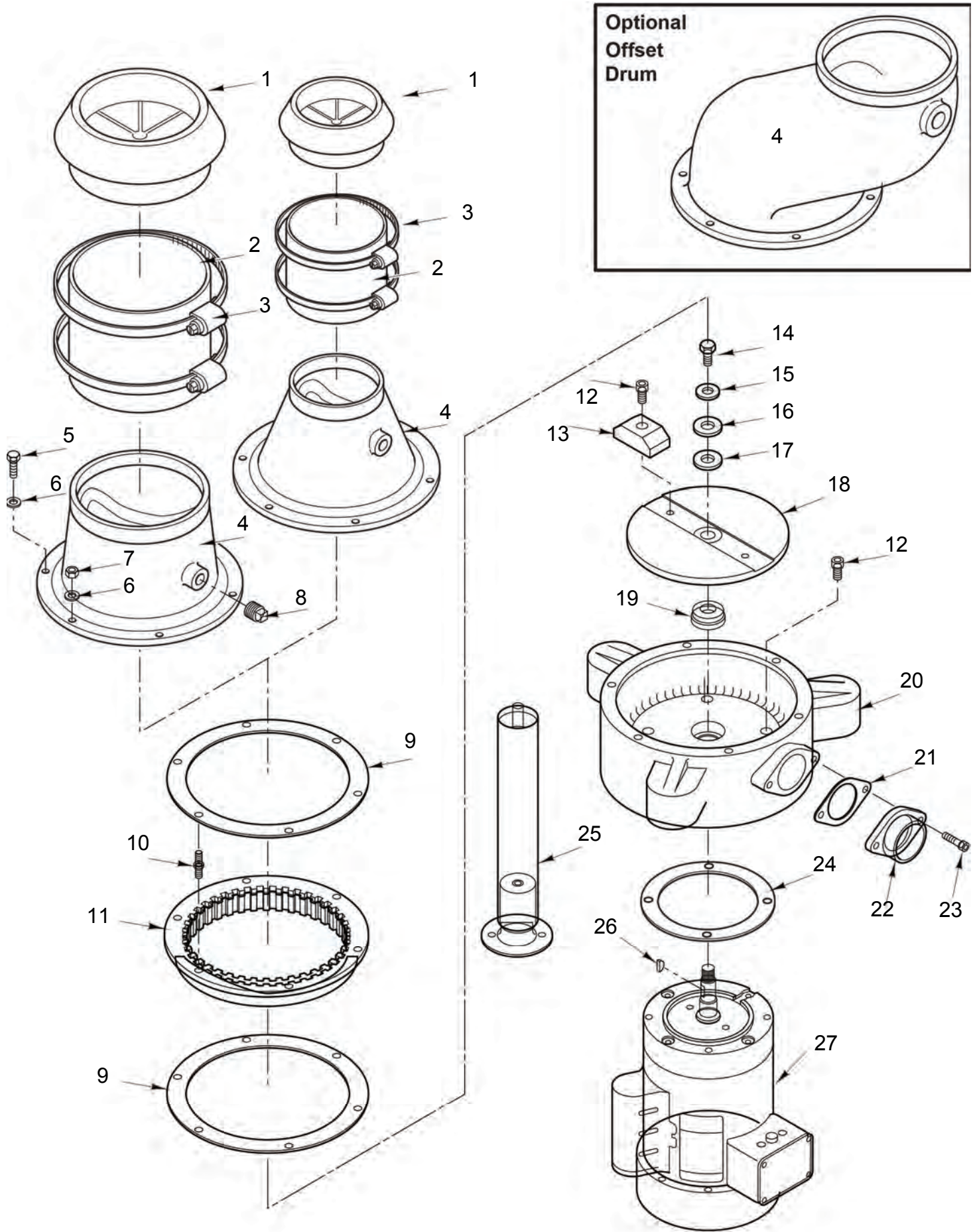

A SERIES REPLACEMENT PARTS DIAGRAM

KEY NO PART NO. NAME: DESCRIPTION/ QTY PER MACH.

1	06-HA-ST4	Silver Saver: 4 1/2"	1
	06-ABC-ST7	Silver Saver: 7"	1
2	06-A-818	Connector Sleeve: 4 1/2" dia. x 8"	1
	06-A-414	Connector Sleeve: 4 1/2" dia. x 4"	1
	06-ABC-834	Connector Sleeve: 7" dia. x 8"	1
	06-ABC-434	Connector Sleeve: 7" dia. x 4"	1
3	08-A-19	Clamp: Connector Sleeve 4 1/2"	2
	08-ABC-33	Clamp: Connector Sleeve 7"	2
4	51-A-11AS	Drum: 4 1/2" Throat	1
	51-A-11S	Drum: 7" Throat	1
	51-A-81	Offset Drum: 7" Throat	1
5	08-HA-22	Screw: Hxhd 5/16-18 x 1, SS	4
6	08-HA-311	Washer: Lock Split 5/16	6
7	08-HA-17	Nut: Hex 5/16-18	2
8	10-5-27.	Pipe Plug: 1/2"	1
9	07-A-10	Gasket: Sizing Ring	2
10	08-HA-16	Centering Stud	2
11	30-A-9	Sizing Ring	1
12	08-5-24.	Screw: Skhd 3/8-16 x3/4 Nyloc SS	2
13	30-A-27	Impact Bar	2
14	08-H-21	Screw: Hxhd 5/16-18 x 3/4 SS Nyloc	1
15	08-HA-311	Washer: Lock Split 5/16	1
16	09-HA-2	Coverplate	1
17	07-HA-3	Gasket: Coverplate	1
18	51-A-1	Rotor	1
	30-A-1	Rotor Assy: w/Impact Bars (Includes 12, 13 & 18)	1
19	07-HA-83	Cartridge Seal	1
	04-HA-263	Install. Tool: HA Cartridge Seal	1
20	51-A-1141	Base	1
21	A-161	Gasket: Discharge Flange	1
22	A-159	Discharge Flange	1
23	A-4120	Screw: 7/16-20x1 S.H.C.S.	2
24	07-HA-5	Gasket: Motor/Base	1
25	09-A-928	Leg Assy w/Foot: 2" X 13.5, SS	3
26	02-HA-100	Key	1

KEY NO. PART NO. NAME: DESCRIPTION/ QTY PER MACH.

MOTOR OPTIONS

27	D-011235060	Motor: 1.5HP/3PH/50 & 60HZ	1
	D-0112160	Motor: 1.5HP/1PH/60HZ	1
	D-0112150	Motor: 1.5HP/1PH/50HZ	1
	D-0235060	Motor: 2HP/3PH/50 & 60HZ	1
	D-02160	Motor: 2HP/1PH/60HZ	1
	D-02150	Motor: 2HP/1PH/50HZ	1
	D-0335060	Motor: 3HP/3PH/50 & 60HZ	1
	D-05360	Motor: 5HP/3PH/60HZ	1

NOT SHOWN

02-5-400	Bearing: #205 UPPER 1.5 & 2HP	1
02-HA-399	Bearing: #203 LOWER 1.5 & 2HP	1
02-BC-401	Bearing: #206 UPPER 3 & 5HP	1
02-5-400	Bearing: #205 LOWER 3 & 5HP	1
RG-1059-22	Drain Coupling	1
40-A-503	A-Complete Renewal Kit	1
40-A-1A	A-Rotor Kit (Includes 12-18)	1
40-A-9A	A-Sizing Ring Kit (Includes 6, 7 & 9-11)	1
40-HA-507	A-Motor Seal Kit (Includes 19 & 24)	1